



VALVE DATA SHEET

Project	포스코퓨처엠 음극제 공장		
Item	Pneumatic On-Off Segmental Ball Valve	Sheet No.	1 OF 4
Service		P&ID No.	
Tag. No.		MFG. No.	
Model No.	YABS-312E3-L	Q'ty (Set)	1

SERVICE CONDITIONS	1	Medium	연필 아주 고운 가루		ACTUATOR	46	Actuator Type	Double Acting Cylinder			
	2		Max. Q	Nor. Q		Min. Q	47	Model No.	B4S		
	3	Flow Rate	kg/hr				48	Close At (bar G)	Open At (bar G)	4.0 4.0	
	4	Inlet Pressure	kgf/cm ² G	미압			49	Fail Position	Last		
	5	Outlet Pressure	kgf/cm ² G				50	Hand-Wheel (Type / Location)	-		
	6	Differential Pressure	kgf/cm ²				51	Painting Color (RAL No.)	RAL 9011		
	7	Inlet Temperature	℃	420			52	Painting Type	PX8576(S)-BLACK(AB-1)		
	8	Specific Gravity	G				I / P POSITIONER	53	Input Signal (mA DC)	-	
	9	Density	kg/m ³					54	Output Pressure (bar G)	-	
	10	Molecular Weight	M.W					55	Type	-	
	11	Viscosity	cPs					56	Enclosure	-	
	12	Predicted SPL	dBA					57	Model No.	-	
	13	Calculated Cv						59	MFG.	-	
	14	Opening Lift	%					POSITION TRANSMITTER	59	Output (mA DC)	-
	15								60	Type	-
	16						61		Model No.	-	
DESIGN	17	Shut Off ΔP			kgf/cm ² G	SOLENOID VALVE	62	Power	DC24V		
	18	Design Pressure			kgf/cm ² G		63	Type	5/2-Way		
	19	Design Temp.			℃		64	Enclosure	IP-66		
LINE	20	Inlet Pipe Size (A) / Sch. No.	100			65	Model No.	ESV-S			
	21	Outlet Pipe Size (A) / Sch. No.	100			66	MFG.	PG			
BODY & TRIM	22	Body Type	Segmental Ball		LIMIT SWITCH & BOX	67	Quantity	Close/Open			
	23	Body Size (A)	Port Size (A)	100		100	68	Type	SPDT		
	24	Trim Design	Guide	Eccentric		Top & Bottom	69	Enclosure	IP-66		
	25	Trim Type	Trim Seal Ring	-		-	70	Model No.	APL-210N		
	26	Rating & End Connection	JIS 10K R.F Flanged			AIR SET	71	MFG.	HKC		
	27	Flange Facing	Spiral Serrated (125~250 AARH)				72	Supply Setting Pressure (bar G)	5.0		
	28		Body	A351-CF8			73	Model No.	AR-1501		
	29	Material	Trim (Ball / Seat)	SUS630 (H.T)		LOCK-UP VALVE	74	Signal Setting Pressure (bar G)	-		
	30		Stem	SUS304			75	Model No.	-		
	31		Bellows	-		SNAP-ACTING RELAY	76	Signal Setting Pressure (bar G)	-		
	32		Packing	Graphite			77	Model No.	-		
	33	Bonnet Type	Long Extension		ACCESSORY	78	Volume Booster	-			
	34	Trim Form	Quick-Open			79	Check Valve	-			
	35	Max.Allow Sound Level (dBA)	-			80	Air-Operated Valve	-			
	36	Required Seat Tightness	ANSI CLASS IV			81	Exhaust Valve	-			
	37	Rated Cv	-			82	Speed-Controller	-			
	38	Stroke	90°			83					
	39	Flow Action To	Direct			84					
	40	Painting Color (RAL No.)	-			85					
	41	Painting Type	-		MISCELLANEOUS	86	Conduit Connection	Air Supply	PT.F 1/4"		
	42					87		Electrical	PF.F 1/2"		
	43					88	Water Seal	-			
	44					89	Tubing Material	316 SS			
	45					90					

NOTE	* 수직배관			
	* Face to Face : 229mm (2차측 확장으로 맞춤)			

0	2024-01-25	For Quotation	E. Y. J	H. S. L	S. S. H
No.	Date	Revision	Prepared By	Checked By	Approved By



VALVE DATA SHEET

Project	포스코퓨처엠 음극제 공장		
Item	Pneumatic On-Off Segmental Ball Valve	Sheet No.	2 OF 4
Service		P&ID No.	
Tag. No.		MFG. No.	
Model No.	YABS-312E3-L	Q'ty (Set)	1

SERVICE CONDITIONS	1	Medium	연필 아주 고운 가루		ACTUATOR	46	Actuator Type	Double Acting Cylinder			
	2		Max. Q	Nor. Q		Min. Q	47	Model No.	B6S		
	3	Flow Rate	kg/hr				48	Close At (bar G)	Open At (bar G)	4.0 4.0	
	4	Inlet Pressure	kgf/cm ² G	미압			49	Fail Position	Last		
	5	Outlet Pressure	kgf/cm ² G				50	Hand-Wheel (Type / Location)	-		
	6	Differential Pressure	kgf/cm ²				51	Painting Color (RAL No.)	RAL 9011		
	7	Inlet Temperature	℃	420			52	Painting Type	PX8576(S)-BLACK(AB-1)		
	8	Specific Gravity	G				I / P POSITIONER	53	Input Signal (mA DC)	-	
	9	Density	kg/m ³					54	Output Pressure (bar G)	-	
	10	Molecular Weight	M.W					55	Type	-	
	11	Viscosity	cPs					56	Enclosure	-	
	12	Predicted SPL	dBA					57	Model No.	-	
	13	Calculated Cv						59	MFG.	-	
	14	Opening Lift	%					POSITION TRANSMITTER	59	Output (mA DC)	-
	15								60	Type	-
	16						61		Model No.	-	
DESIGN	17	Shut Off ΔP			kgf/cm ² G	SOLENOID VALVE	62	Power	DC24V		
	18	Design Pressure			kgf/cm ² G		63	Type	5/2-Way		
	19	Design Temp.			℃		64	Enclosure	IP-66		
LINE	20	Inlet Pipe Size (A) / Sch. No.	150			65	Model No.	ESV-S			
	21	Outlet Pipe Size (A) / Sch. No.	150			66	MFG.	PG			
BODY & TRIM	22	Body Type	Segmental Ball		LIMIT SWITCH & BOX	67	Quantity	Close/Open			
	23	Body Size (A)	Port Size (A)	150		150	68	Type	SPDT		
	24	Trim Design	Guide	Eccentric		Top & Bottom	69	Enclosure	IP-66		
	25	Trim Type	Trim Seal Ring	-		-	70	Model No.	APL-210N		
	26	Rating & End Connection	JIS 10K R.F Flanged			AIR SET	71	MFG.	HKC		
	27	Flange Facing	Spiral Serrated (125~250 AARH)				72	Supply Setting Pressure (bar G)	5.0		
	28		Body	A351-CF8			73	Model No.	AR-1501		
	29	Material	Trim (Ball / Seat)	SUS630 (H.T)		LOCK-UP VALVE	74	Signal Setting Pressure (bar G)	-		
	30		Stem	SUS304			75	Model No.	-		
	31		Bellows	-		SNAP-ACTING RELAY	76	Signal Setting Pressure (bar G)	-		
	32		Packing	Graphite			77	Model No.	-		
	33	Bonnet Type	Long Extension		ACCESSORY	78	Volume Booster	-			
	34	Trim Form	Quick-Open			79	Check Valve	-			
	35	Max.Allow Sound Level (dBA)	-			80	Air-Operated Valve	-			
	36	Required Seat Tightness	ANSI CLASS IV			81	Exhaust Valve	-			
	37	Rated Cv	-			82	Speed-Controller	-			
	38	Stroke	90°			83					
	39	Flow Action To	Direct			84					
	40	Painting Color (RAL No.)	-			85					
	41	Painting Type	-		MISCELLANEOUS	86	Conduit Connection	Air Supply	PT.F 1/4"		
	42					87		Electrical	PF.F 1/2"		
	43					88	Water Seal	-			
	44					89	Tubing Material	316 SS			
	45					90					

NOTE	* 수직배관						
	* Face to Face : 260mm (2차측 확장으로 맞춤)						
0	2024-01-25	For Quotation			E. Y. J	H. S. L	S. S. H
No.	Date	Revision			Prepared By	Checked By	Approved By



VALVE DATA SHEET

Project	포스코퓨처엠 음극제 공장		
Item	Pneumatic On-Off Segmental Ball Valve	Sheet No.	3 OF 4
Service		P&ID No.	
Tag. No.		MFG. No.	
Model No.	YABS-312E3-S	Q'ty (Set)	1

SERVICE CONDITIONS	1	Medium	연필 아주 고운 가루		ACTUATOR	46	Actuator Type	Double Acting Cylinder		
	2		Max. Q	Nor. Q		Min. Q	47	Model No.	B6S	
	3	Flow Rate	kg/hr				48	Close At (bar G)	Open At (bar G)	4.0 4.0
	4	Inlet Pressure	kgf/cm ² G	미압			49	Fail Position	Last	
	5	Outlet Pressure	kgf/cm ² G				50	Hand-Wheel (Type / Location)	-	
	6	Differential Pressure	kgf/cm ²				51	Painting Color (RAL No.)	RAL 9011	
	7	Inlet Temperature	℃	200			52	Painting Type	PX8576(S)-BLACK(AB-1)	
	8	Specific Gravity	G				I / P POSITIONER	53	Input Signal (mA DC)	-
	9	Density	kg/m ³					54	Output Pressure (bar G)	-
	10	Molecular Weight	M.W					55	Type	-
	11	Viscosity	cPs					56	Enclosure	-
	12	Predicted SPL	dBA					57	Model No.	-
	13	Calculated Cv						59	MFG.	-
	14	Opening Lift	%					POSITION TRANSMITTER	59	Output (mA DC)
	15						60		Type	-
	16						61		Model No.	-
DESIGN	17	Shut Off ΔP			kgf/cm ² G	SOLENOID VALVE	62	Power	DC24V	
	18	Design Pressure			kgf/cm ² G		63	Type	5/2-Way	
	19	Design Temp.			℃		64	Enclosure	IP-66	
LINE	20	Inlet Pipe Size (A) / Sch. No.	200			65	Model No.	ESV-S		
	21	Outlet Pipe Size (A) / Sch. No.	200			66	MFG.	PG		
BODY & TRIM	22	Body Type	Segmental Ball		LIMIT SWITCH & BOX	67	Quantity	Close/Open		
	23	Body Size (A)	Port Size (A)	200		200	68	Type	SPDT	
	24	Trim Design	Guide	Eccentric		Top & Bottom	69	Enclosure	IP-66	
	25	Trim Type	Trim Seal Ring	-		-	70	Model No.	APL-210N	
	26	Rating & End Connection	JIS 10K R.F Flanged			AIR SET	71	MFG.	HKC	
	27	Flange Facing	Spiral Serrated (125~250 AARH)				72	Supply Setting Pressure (bar G)	5.0	
	28	Material	Body	A351-CF8			73	Model No.	AR-1501	
	29		Trim (Ball / Seat)	SUS630 (H.T)		LOCK-UP VALVE	74	Signal Setting Pressure (bar G)	-	
	30		Stem	SUS304			75	Model No.	-	
	31		Bellows	-		SNAP-ACTING RELAY	76	Signal Setting Pressure (bar G)	-	
	32		Packing	Graphite			77	Model No.	-	
	33	Bonnet Type	Extension		ACCESSORY	78	Volume Booster	-		
	34	Trim Form	Quick-Open			79	Check Valve	-		
	35	Max.Allow Sound Level (dBA)	-			80	Air-Operated Valve	-		
	36	Required Seat Tightness	ANSI CLASS IV			81	Exhaust Valve	-		
	37	Rated Cv	-			82	Speed-Controller	-		
	38	Stroke	90°			83				
	39	Flow Action To	Direct			84				
	40	Painting Color (RAL No.)	-			85				
	41	Painting Type	-		MISCELLANEOUS	86	Conduit Connection	Air Supply	PT.F 1/4"	
	42					87		Electrical	PF.F 1/2"	
	43					88	Water Seal	-		
	44					89	Tubing Material	316 SS		
	45					90				

NOTE	* 수직배관						
	* Face to Face : 297mm (2차측 확장으로 맞춤)						
0	2024-01-25	For Quotation			E. Y. J	H. S. L	S. S. H
No.	Date	Revision			Prepared By	Checked By	Approved By

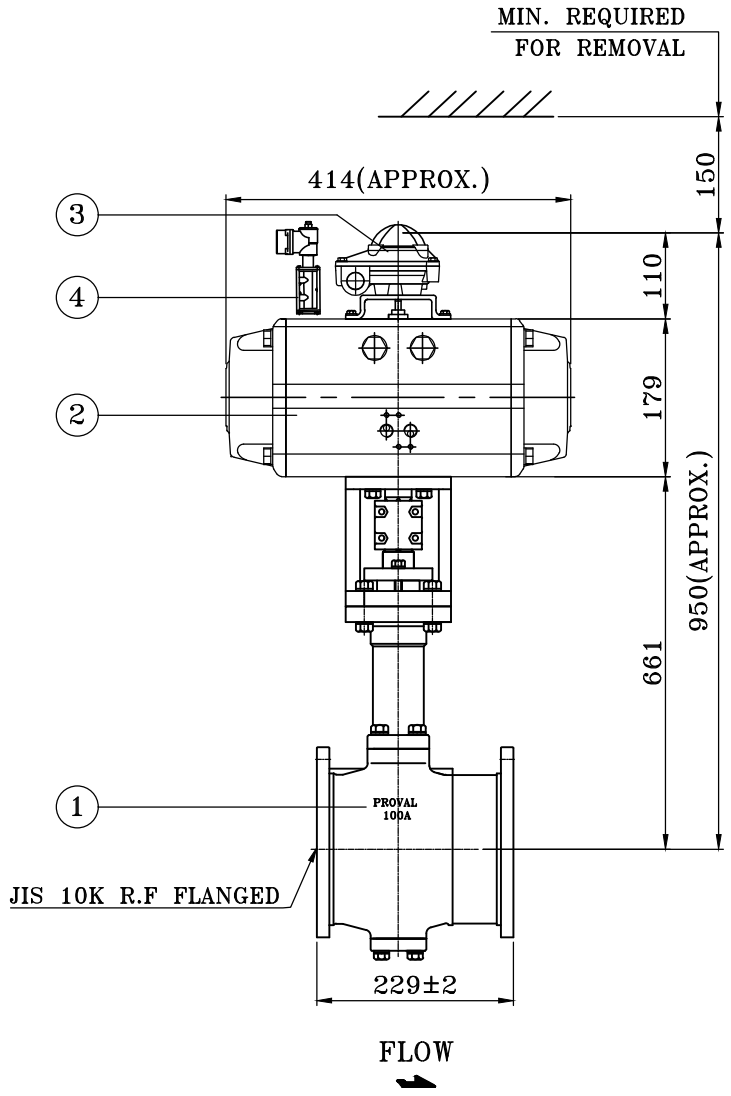

ACTUATOR LOCATION

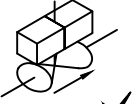
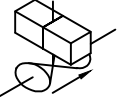
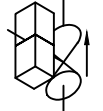
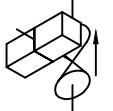
 STANDARD <input checked="" type="checkbox"/>	 TYPE2 <input type="checkbox"/>
 TYPE3 <input type="checkbox"/>	 TYPE4 <input type="checkbox"/>

- Tag No. :

4	Solenoid Valve		
3	Limit Switch & Box		
2	Actuator		
1	Body	A351-CF8	
No.	Name Of Parts	Material	Remark
Model No.	YABS-312E3-L	Size	100A
DWG. Name Pneumatic Shut-Off Segmental Ball Valve			
DRAW'N	M.J Park	APP'D	J.S Noh
 PROVAL Co.,Ltd.		Date	2024.01.25
		Rev.	0
		Sheet No.	1 of 4

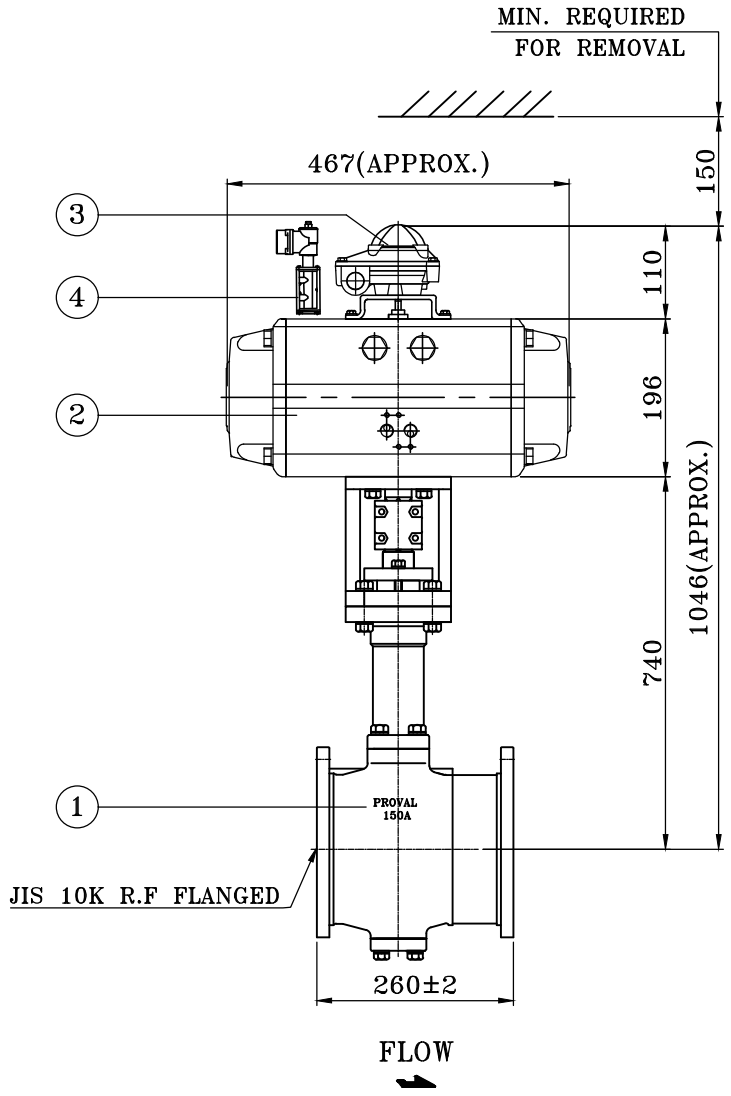

ACTUATOR LOCATION

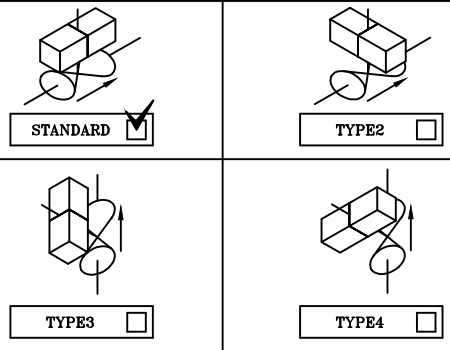

- Tag No. :

4	Solenoid Valve		
3	Limit Switch & Box		
2	Actuator		
1	Body	A351-CF8	
No.	Name Of Parts	Material	Remark
Model No.	YABS-312E3-L	Size	150A
DWG. Name	Pneumatic Shut-Off Segmental Ball Valve		
DRAW'N	M.J Park	APP'D	J.S Noh
PROVAL Co.,Ltd.		Date	2024.01.25
		Rev.	0
		Sheet No.	2 of 4

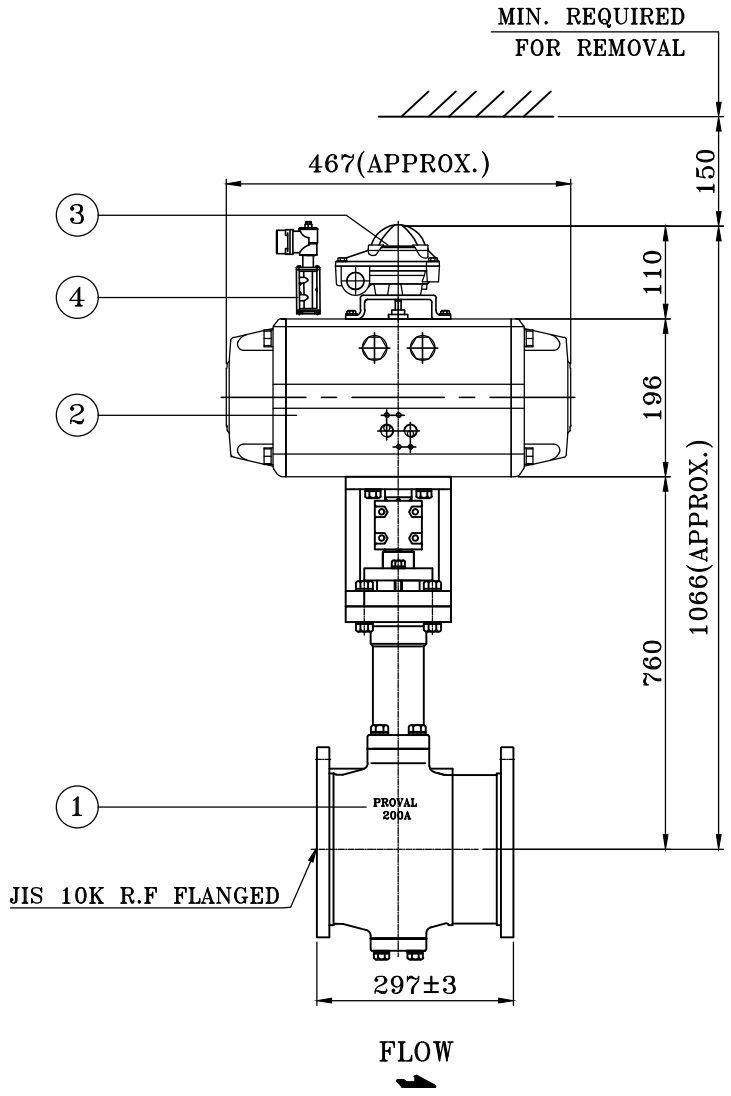

ACTUATOR LOCATION

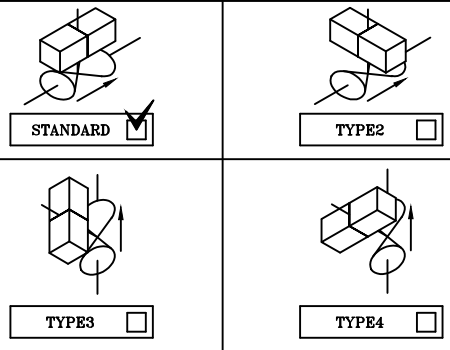

- Tag No. :

4	Solenoid Valve		
3	Limit Switch & Box		
2	Actuator		
1	Body	A351-CF8	
No.	Name Of Parts	Material	Remark
Model No.	YABS-312E3-S	Size	200A
DWG. Name	Pneumatic Shut-Off Segmental Ball Valve		
DRAW'N	M.J Park	APP'D	J.S Noh
PROVAL Co.,Ltd.		Date	2024.01.25
		Rev.	0
		Sheet No.	3 of 4