



VALVE DATA SHEET

Project			
Item	Pneumatic Control Hi-Performance Butterfly Valve	Sheet No.	15 OF 15
Service		P&ID No.	
Tag. No.	LUB-TCV-L01	MFG. No.	20220945
Model No.	YABHB-222E1	Q'ty (Set)	1

SERVICE CONDITIONS	1 Medium		Water		Liquid		ACTUATOR	46	Actuator Type	Single Acting Cylinder		
	2			Max. Q	Nor. Q	Nin. Q		47	Model No.	B2SR		
	3	Flow Rate	kg/hr					48	Close At (bar G)	Open At (bar G)	3.5	2.5
	4	Inlet Pressure	kgf/cm ² G					49	Fail Position (Signal / Air)	Open		
	5	Outlet Pressure	kgf/cm ² G					50	Hand-Wheel (Type / Location)	-		
	6	Differential Pressure	kgf/cm ²					51	Painting Color (RAL No.)	RAL 5019		
	7	Inlet Temperature	°C					52	Painting Type	Polyurethane		
	8	Specific Gravity	G					I / P POSITIONER	53	Input Signal (mA DC)	4 ~ 20	
	9	Density	kg/m ³						54	Output Pressure (bar G)	1.4 ~ 2.8	
	10	Molecular Weight	M.W						55	Type	Conventional	
	11	Viscosity	cPs						56	Enclosure	ExdIIBT5	
	12	Predicted SPL	dBA						57	Model No.	TS600R	
	13	Calculated Cv							58	MFG.	TSC	
	14	Opening Lift	%						POSITION TRANSMITTER	59	Output (mA DC)	-
	15							60		Type	-	
	16							61		Model No.	-	
DESIGN	17	Shut Off ΔP		kgf/cm ² G		SOLENOID VALVE	62	Power	-			
	18	Design Pressure		kgf/cm ² G			63	Type	-			
	19	Design Temp.		°C			64	Enclosure	-			
LINE	20	Inlet Pipe Size (A) / Sch. No.	80			65	Model No.	-				
	21	Outlet Pipe Size (A) / Sch. No.	80			66	MFG.	-				
BODY & TRIM	22	Body Type	Butterfly (Hi-Performance)		LIMIT SWITCH	67	Quantity	-				
	23	Body Size (A)	Port Size (A)	80		80	68	Type	-			
	24	Trim Design	Guide	Eccentric		Top & Bottom	69	Enclosure	-			
	25	Trim Type	Trim Seal Ring	-		-	70	Model No.	-			
	26	Rating & End Connection	JIS 10K R.F Wafer			71	MFG.	-				
	27	Flange Facing	Smooth-Finish		AIR SET	72	Air Supply Pressure (bar G)	4.0				
	28	Material	Body	SCS13		73	Model No.	AR-1501				
	29		Plug / Disc / Ball	SUS304		ACCESSORY	74	Lock-Up Valve	-			
	30		Seat	RTFE			75	Volume Booster	-			
	31		Cage	-			76	Snap Acting Relay	-			
	32		Stem	316 SS			77	Check Valve	-			
	33	Packing	PTFE		78		Air-Operated Valve	-				
	34	Bonnet Type	Standard		79		Exhaust Valve	-				
	35	Trim Form	Modified Linear		80		Speed-Controller	-				
	36	Max.Allow Sound Level (dBA)	Less than 85		81							
	37	Required Seat Tightness	ANSI CLASS VI		82							
	38	Rated Cv	190		83							
	39	Stroke	90°		84							
	40	Flow Action To	Direct		85							
	41	Painting Color (RAL No.)	-		MISCELLANEOUS	86	Conduit Connection	Air Supply	PT.F 1/4"			
	42	Painting Type	-			87		Electrical	PF.F 1/2"			
	43					88	Water Seal	-				
	44					89	Tubing Material	316 SS				
	45					90						
	NOTE											

A	2022-09-19	For Approval			S. J. K	H. S. L	S. S. H
No.	Date	Revision			Prepared By	Checked By	Approved By

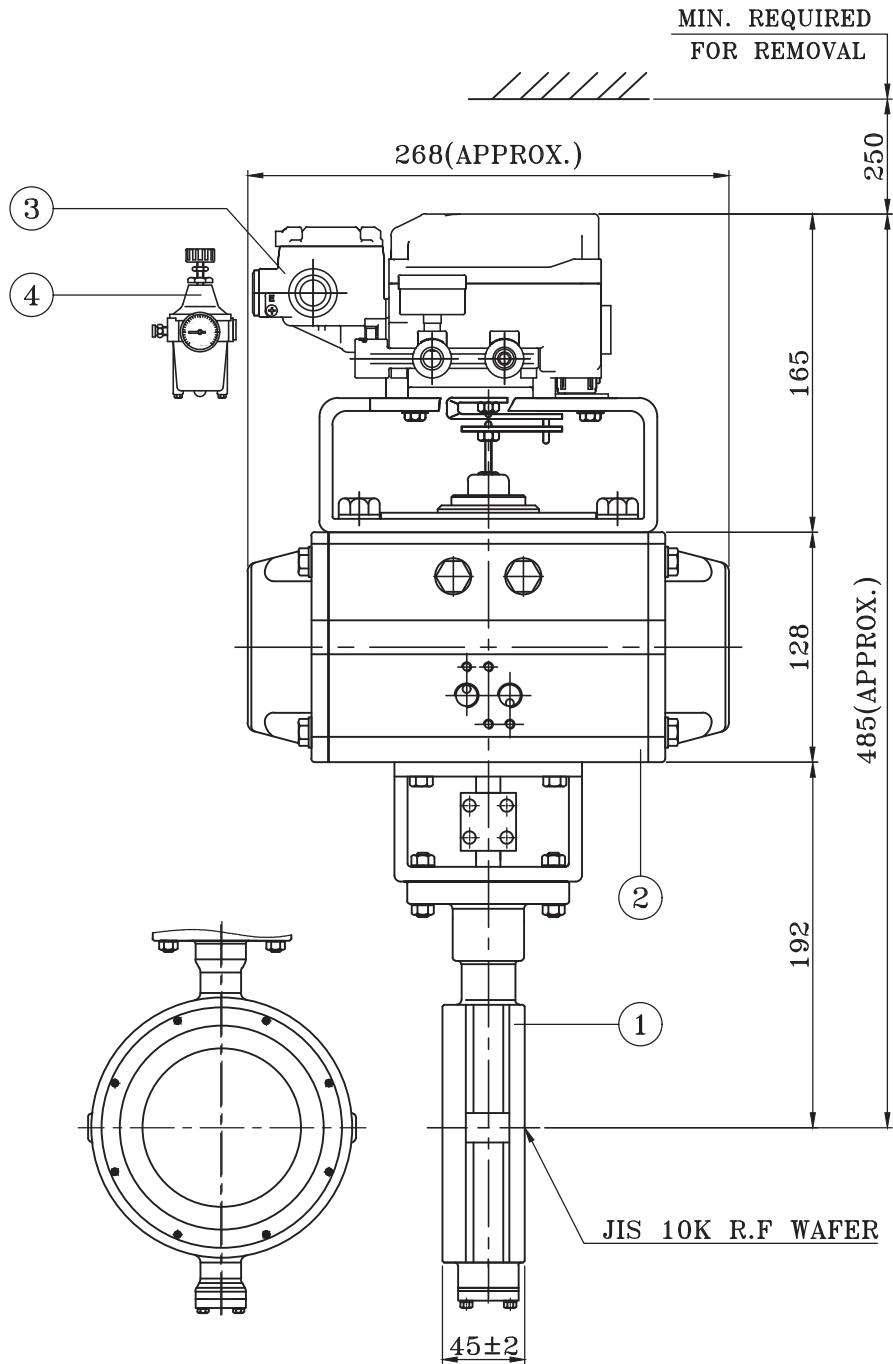

Actuator Location

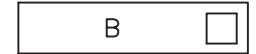
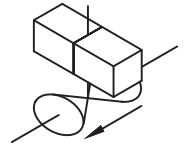
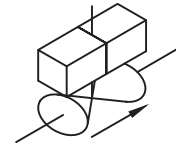

- Tag No. : LUB-TCV-L01

4	Air-Set		
3	Limit Switch		
2	Actuator		
1	Body	SCS13	
No.	Name Of Parts	Material	Remark
Model No.	YABHB-222E1	Size	80A
DWG. Name		Pneumatic Control Hi-Performance Butterfly Valve	
DRAW'N	J.H Bae	APP'D	J.S Noh
PROVAL Co.,Ltd.		Date	2022.09.23
		Rev.	A
		Sheet No.	15 of 15