



CONTROL VALVE DATA SHEET

Item	PNEUMATIC CONTROL 2WAY DIAPHRAGM VALVE	Sheet No.	
Service		Item No.	
Tag. No.		MFG. No.	
Model No.	YADT-122E1	Q'ty (Set)	1

SERVICE CONDITIONS	1	Medium	State	ACID, GAS			
	2			Max. Q	Nor. Q	Min. Q	Etc.
	3	Flow Rate	NM3/H				
	4	Inlet Pressure	MMH2O				
	5	Outlet Pressure	kgf/cm ² G				
	6	Inlet Temperature	°C				
	7	Specific Gravity	G				
	8	Molecular Weight	M.W				
	9	Viscosity	cPs				
	10	Predicted SPL	dba				
	11	Calculated Cv					
	12	Opening Lift	%				
	13						

LINE	14	Shut Off ΔP	kgf/cm ² G	INLET	Size (A)	40A		OUTLET	Size (A)	40A
	15	Design Pressure	kgf/cm ² G		Schedule No.				Schedule No.	
	16	Design Temp.	°C		Material				Material	
	17	Location Condition	Vertical		Insulation (mm)				Insulation (mm)	

BODY & TRIM	18	Type of Body	GLOBE (2-WAY)		AIR SET	49	Option	Filter + Regulator + Gauge	
	19	Body Size (A)	Port Size (A)	40A		40A	50	Model	TS-300
	20	Trim Design	Guiding	DIAPHRAGM		TOP	51	MFG.	TISSIN
	21	Rating & End Connection		JIS (KS) 10K		POSITION TRANSMITTER	52	Output (mA DC)	
	22	Flange Facing		Smooth-Finish			53	Type	
	23	Material	Body	FCD-S			54	Model	
	24		Trim(Plug/Seat)	PFA		55	MFG.		
	25		Packing	PTFE		BOOSTER RELAY	56	Quantity (Set)	
	26	Bonnet Type		Standard			57	Model	
	27	Trim Form		Equal %			58	MFG.	
	28	Max.Allow Sound Level (dba)		85		LOCK UP VALVE	59	Lock Up Setting Pressure (kgf/cm ² G)	
	29	Required Seat Tightness		ANSI CLASS VI			60	Model	
	30	Rated Cv		25			61	MFG.	
	31	Stroke (mm)		20		SNAP ACTING RELAY	62	Fail Setting Pressure (kgf/cm ² G)	
32	Flow Action To		Direct		63		Model		
33	Painting Color		-		64		MFG.		
34	Painting Type		-		SOLENOID VALVE	65	Power		
35	Type of Actuator		Single Acting Diaphragm			66	Type		
36	Air Supply Pressure (kgf/cm ² G)		3.2			67	Enclosure		
37	Fail Position		Close			68	Model		
38	Hand-Wheel (Location)		None			69	MFG.		
39	Painting Color (Munsell No.)		std		LIMIT SWITCH	70	Quantity		
40	Painting Type		std			71	Type		
41						72	Enclosure		
42						73	Model		
I/P POSITIONER	43	Input Signal (mA DC)		4 - 20		74	MFG.		
	44	Output Pressure (kgf/cm ² G)		1.4 ~ 2.8		MISCELLANEOUS	75	Conduit Connection	Air Supply NPT.F 1/4"
	45	Type		E/P Positioner			76	Electrical	NPT.F 1/2"
	46	Enclosure		Explosion Proof		77	Tubing Material		
	47	Model No.		TS600L		78			
	48	MFG.		TISSIN		79			

NOTE								

0	2024-11-14	For Approval	H.S.LEE	H.S.LEE	H.S.LEE
No.	Date	Revision	Prepared By	Checked By	Approved By

DIMENSIONS			UNIT : mm	
MODEL	L	Y	H	PT.F 1 / 4" (AIR SUPPLY)
YADT-122E1	165	270	480	

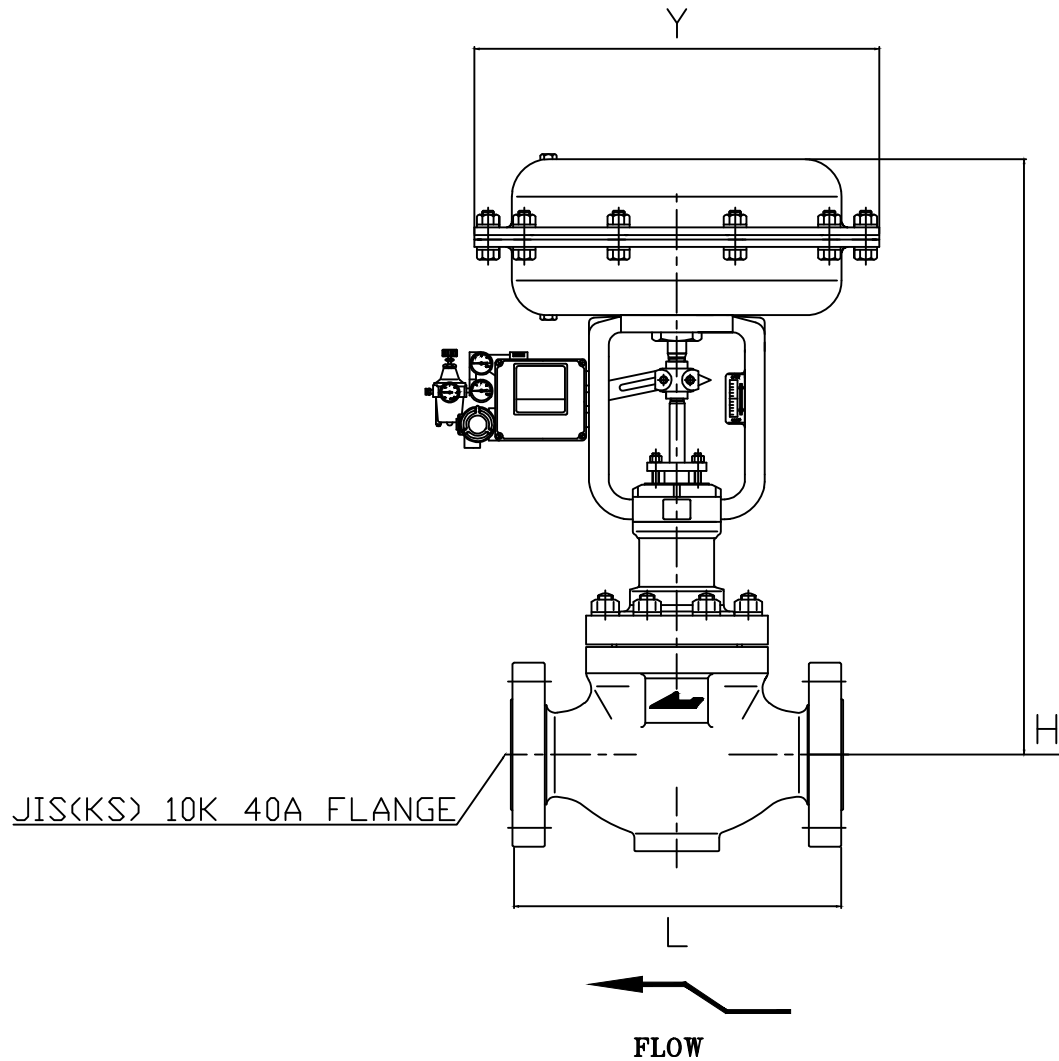

	AIR SET		
	E/P POSITIONER		
	ACTUATOR		
P.NO.	PART NAME	MATERIAL	REMARK

PNEUMATIC CONTROL 2-WAY DIAPHRAGM VALVE

MODEL.		YADT-122E1		
DWG	DES'N	CHK'D	APP'D	SCALE : N/S
			H.S.LEE	DWG NO



PROVAL Co., Ltd.